

Flock-grind'ing Ma-chine'. A case of the form of a hollow cone, containing a revolving cylinder of the form of the frustum of a solid cone. Both are provided with spirally arranged knives, held between segmental binder-plates. Apertures at both ends are provided, so that the machine may be fed and run in either direction, to sharpen the knives and grind at the same time.

M'Allister's, 1870, has a cylinder of oblique blades operating upon vertical parallel blades on the concave beneath.

In some cases the grinder is a frustum of a cone discharging at the base.

In the example (Fig. 2028), the box has radial agitators on a vertical, rotating shaft. The endless

Fig. 2028.

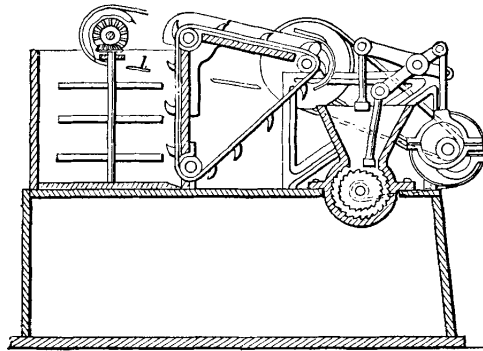

Flock-Grinder.

apron passes up one side, and has cups carrying up the material and conveying it to the hopper of the tearing cylinder. The material is forced down upon the tearing cylinder by reciprocal plungers.