

LOOM ATTACHMENTS

UNDERCAMS FOR OTHER THAN TWO-HARNESS WORK

INTRODUCTION

1. Cams in General.—As shedding by cams is the most perfect form of shedding ever devised, it will be found that cams are employed in every case where the expense attached to them does not prohibit their use, or where their number does not render them impracticable on account of the great amount of space occupied. In the United States, cams are generally employed on three-, four-, five-, or six-harness work; in England, even a larger number of harnesses are frequently operated in this manner. The classes of fabrics principally woven in cam-looms are *plains*, *twills*, and *sateens*.

2. In considering the possibilities of cams, there are always certain limitations to be dealt with. If a cam is constructed for two-harness work, it is impossible to use it in weaving any cloth that requires a larger number of harnesses; consequently, when a cam-loom is changed from one kind of weave to another, it is always necessary to change the cams to suit the requirements. This necessitates the loss of time, especially in a mill that is constantly changing from one class of work to another. In many cases special cams must be constructed for special work, thus adding greatly to the expense of operation. Moreover, as undercams act directly on the treadles only, when depressing the harnesses, some arrangement must be adopted by means of which they

For notice of copyright, see page immediately following the title page

may indirectly raise the harnesses. This is accomplished by the use of a strap-and-roller connection placed at the top of the loom. This arrangement, however, places certain limitations on the movement of the harnesses. It will be remembered that the action of the cam in pressing down one harness serves to raise another harness by means of the straps and rollers just referred to. Consequently, one harness cannot be raised unless another is lowered; the opposite is equally true—that is, it is impossible to lower a harness without raising another one. This will be found to be true in every case where cams are used in combination with strap-and-roller connections, the number of cams employed not changing the conditions.

3. Suppose, for example, that a cam-loom is on three-harness work, two harnesses being up on each pick and one down, producing what is known as a $\frac{2}{1}$ weave (read two up, one down); then the ratio of harnesses raised to those lowered must always be the same, that is, on every pick that is placed in the cloth there must be two harnesses up and one down. The same would be true if more harnesses were used. Take for example a cam-loom operating four harnesses, the cams being so constructed that two harnesses will be up and two down, producing a $\frac{2}{2}$ weave; then on every pick of the weave there must be the same ratio of harnesses raised to those lowered.

The order in which the cams change the harnesses, however, may be altered. Suppose that a cam-loom is running on four-harness work, the cams being so constructed that three harnesses will be up on each pick and one down. These cams may be placed on the shaft of the loom in such a manner that the first harness will be lowered on the first pick, the second harness on the second pick, the third harness on the third pick, and the fourth harness on the fourth pick. This produces a regular *four-harness twill*. Again, the cams may be so placed on the shaft that the first harness will be lowered on the first pick, the second harness on the second pick, the fourth harness on the third pick, and the

third harness on the fourth pick; this will produce what is termed a *broken crow weave*. Cams for more than three harnesses are usually made separate in order that they may permit this interchanging of their order of operation.

After one harness has been lowered or raised, it cannot again be lowered or raised until all the other harnesses employed in the weave have been moved in the same manner. Thus, in the case of the weave just referred to, where one harness is down and three up, if the first harness is lowered on the first pick, all the other harnesses must be lowered before that harness can again be dropped.

4. The order in which the harnesses are changed, where only one harness is raised or lowered on each pick, is generally shown by means of numbers, which designate the number of the harness and also on which pick each harness is to be moved. Thus, in the case of the four-harness twill just referred to, where one harness is down and three up on each pick, the harnesses could be said to be lowered in 1-2-3-4 order; that is, the first harness is lowered on the first pick, the second harness on the second pick, the third harness on the third pick, and the fourth harness on the fourth pick, the figures representing which harness is moved, while the order in which the figures stand show on which pick each harness is moved.

The different orders of moving four harnesses when operated by cams constructed so as to give one harness down and three up on each pick are as follows:

- | | |
|------------|------------|
| 1. 1-2-3-4 | 4. 1-3-4-2 |
| 2. 1-2-4-3 | 5. 1-4-2-3 |
| 3. 1-3-2-4 | 6. 1-4-3-2 |

CONSTRUCTION OF DIFFERENT CAMS

5. In constructing cams for different kinds of work there are certain points that should always be borne in mind in order to fully comprehend the different steps necessary. The outer circle of construction, *h d*, Fig. 1, should first be divided into a certain number of equal parts that will be the

same as the number of picks to the round; that is, the number of picks that are inserted in the cloth while the cam is making one complete revolution. The term number of picks to the round also generally indicates the number of harnesses that are employed in the weave. Thus, in speaking of a three-harness twill, a twill would be understood that would be woven on three harnesses employing three cams and, consequently, three picks would be inserted while one cam was making a complete revolution. It is not necessary, however, that the number of picks to the round should limit the number of harnesses on which the weave could be woven. However, it will generally be found to be the case on cam-looms that the number of harnesses employed in the weave will indicate the number of picks to the round, and vice versa.

Each one of these equal parts into which the cam is divided will represent one pick of the weave, but since one harness is being lowered while another is being raised, *one-half the change part of one cam will always overlap one-half of the change part of another cam.* The length of dwell of the cam should always be decided on first and marked off on the outer circumference of construction. A dwell equal to the time that it takes the loom to make one-half a pick, or, as it is known, one-half a pick dwell, will be allowed in all cams illustrated here.

FOUR-HARNESS CAMS

6. Cams for $\frac{3}{4}$ Twill.—Fig. 1 shows the construction of a cam that would be suitable for a four-harness twill weave, three harnesses being up and one down on each pick. Two repeats of the weave, in both ends and picks, produced by cams of this construction are also shown in this illustration. In the complete set of cams for this weave, there would be four cams similar to the one shown in Fig. 1. Each cam, however, is constructed in exactly the same manner, with the exception of a slightly greater throw being given to each succeeding cam moving toward the back of the loom, the object of this being to produce an even shed in front of the reed.

In constructing cams for any class of weaves, there are certain instructions that will be found common to all. The inner circle representing the cam-shaft should always be drawn first. This circle is shown at *b*, Fig. 1. To the radius used in drawing the circle of the cam-shaft, add the thickness of the hub of the cam; and with this new radius

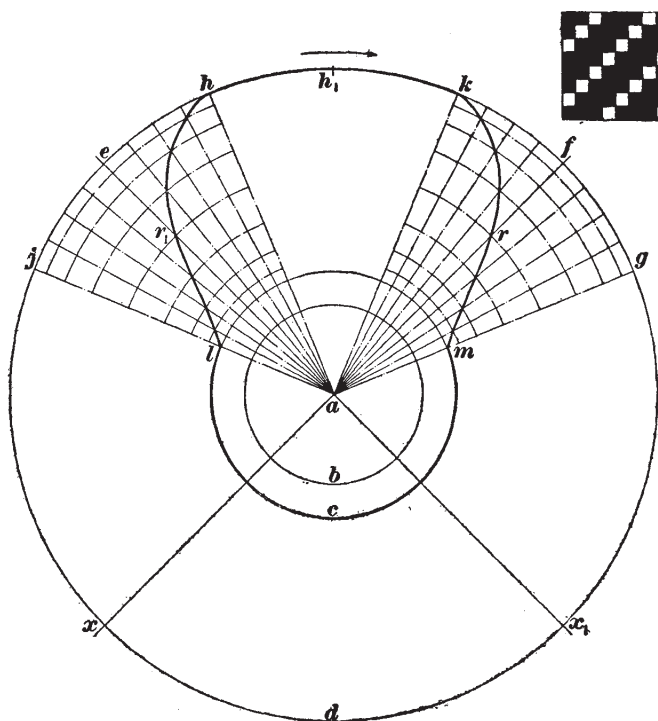

FIG. 1

describe another circle having the same center as the circle previously drawn. This second circle represents the inner throw of the cam and is shown at *c*, Fig. 1. To the radius last used, add the entire throw of the cam; and with the same center describe a third circle, which will represent the outer throw of the cam. This circle is shown at *d*, Fig. 1. After describing these different circles, divide the outer

circle into the same number of equal parts as there are picks to the round.

As previously stated, these instructions apply to the construction of any cam. The number of cams employed, the time the harnesses are to remain up or down, or, in short, any circumstances whatever do not interfere in the slightest with this method of construction.

7. As the cam shown in Fig. 1 is for four-harness work, the circle d must be divided into four equal parts, as shown by the arcs fe , ex , xx_1 , and x_1f . The cam will move the distance of one arc during one pick and will therefore make one complete revolution in the time that it takes to place four picks in the cloth. The time occupied by the dwell of the cam is to be equal to one-half of the time occupied by one pick, and since the cam moves through one of the four equal arcs during one pick, half of the space occupied by any one of these arcs may be taken to represent that part of the cam during which the harness is stationary. Therefore, divide the arc ef into four equal parts eh , hh_1 , h_1k , and kf , and select the two central ones hh_1 and h_1k as the dwell, equal to one-half of ef .

Since the dwell of the cam is to occupy one-half of a pick, one-half the pick, $eh + kf$, will remain in which to construct change parts of the cam. Further, since one-half of each period of change is to be taken from each of the adjoining picks, lay off arcs fg and ej on arcs fx_1 and ex , respectively, each of the former arcs being equal to kf or eh . The first change will now take place during the arc gk , the dwell during the arc hk , while the arc hj marks the change during which the harness will return to its initial position.

8. It should be noted that the arc fg occupies one-quarter of the arc x_1f , which represents the distance through which the cam moves during one pick. The same is equally true of the arc ej with reference to the arc ex . This is in accordance with what has previously been stated in regard to one-half of the change part of one cam overlapping one-half of the change part of another cam. This may be more readily

understood if it is remembered that as one harness is being depressed by one cam another harness is being raised, the two harnesses becoming level at a point that marks half the distance of their rise and fall.

It may further be stated that if the time occupied in changing is one-half of a pick, as in Fig. 1, then the harnesses pass at a point reached after the loom has moved one-quarter of a pick; but if the time occupied in changing is one-third of a pick, the harnesses will pass each other at a point reached after the loom has moved one-sixth of a pick. Therefore, a cam constructed after the manner of the one shown in Fig. 1 must move through the distance represented on the outer circle by the arc hj when allowing the harness to rise, while in depressing the harness it must move through the distance represented on the outer circle by the arc kg . Therefore, the arc hk , which represents half a pick, is taken for the dwell of the cam, while the arcs hj , kg , each of which represents half a pick, are utilized for the construction of the change parts of the cam.

9. Next divide the arcs jh , kg into any number of equal parts; eight are used here, but it will readily be seen that the more parts into which these spaces are divided, the more accurately will the lines of the cam be derived from them. Draw lines from these points of division to the center of the circle. Proceed in the same manner as was adopted in laying out the lines of the cam for two-harness work; that is, divide the lines jl and mg into the same number of unequal parts, commencing at the circle c with a small space and gradually increasing this until the center of the line is reached, when it is reduced again proportionately. With the center a and radii equal to the distances from the center to the points of division, draw arcs cutting the lines previously drawn. The points formed by the intersection of these arcs and radial lines are then connected by the symmetrical curves hl and km . This will give the necessary lines, and as a result the cam $hlc mk$ will be obtained.

It will be noticed that at the points r and r_1 , which mark half

the drop and lift of the cam, the harness operated by this cam will be level with the harness that is passing it; consequently, the central part of the lift of one cam is passing the central part of the drop of another cam.

10. Cams for $\frac{2}{3}$ Twill.—In the case of the cam previously illustrated, each harness must be held down during the time that it takes the loom to make but a single pick. In a large number of weaves, however, the harnesses must be kept down for a longer time than this. An illustration of a cam of this type is found in one constructed for a four-harness twill having two harnesses up and two down on each pick. A cam suitable for this weave will cause the harness that it operates to be depressed during two picks of the loom and will also allow the harness to be raised during two picks. However, in a weave of this character there will be two harnesses changing on each pick, one being lowered and another raised.

Fig. 2 represents the construction of a cam suitable for such a weave. The circles b , c , and d are drawn in a manner similar to the construction of all cams. The outer circle is then divided into four equal parts, since there must be four cams to operate the harnesses for this weave. These parts are represented by the arcs xx_1 , x_1x_2 , x_2x_3 , and x_3x .

As previously stated, this cam holds the harness down while two picks are being made by the loom, but it should be noted that during half a pick the cam must be changing the harness; therefore, that part of the outer circle d that is to form the line of the cam must represent one and one-half picks. Any part of the circle d that represents one and one-half picks may be taken as this part of the cam. In Fig. 2, it is represented by the arc hdk . This arc is obtained by adding to each side of the arc xdx_3 a space equal to one-quarter of a pick. Since the arc xdx_3 is equal to one pick, and the arcs xk and x_3h are each equal to one-quarter of a pick, the arc hdk must be equal to one and one-half picks.

From the points k and h , measure off on the outer circumference arcs that will represent the space moved through by

the cam during one-half of a pick, after the manner explained in Art. 7. This will give the arcs kg , hj , in which the change parts of the cam are to be drawn. Divide these arcs into equal parts by lines drawn from the center to the circumference of the outer circle; then by drawing arcs of different circles divide these lines into unequal spaces.

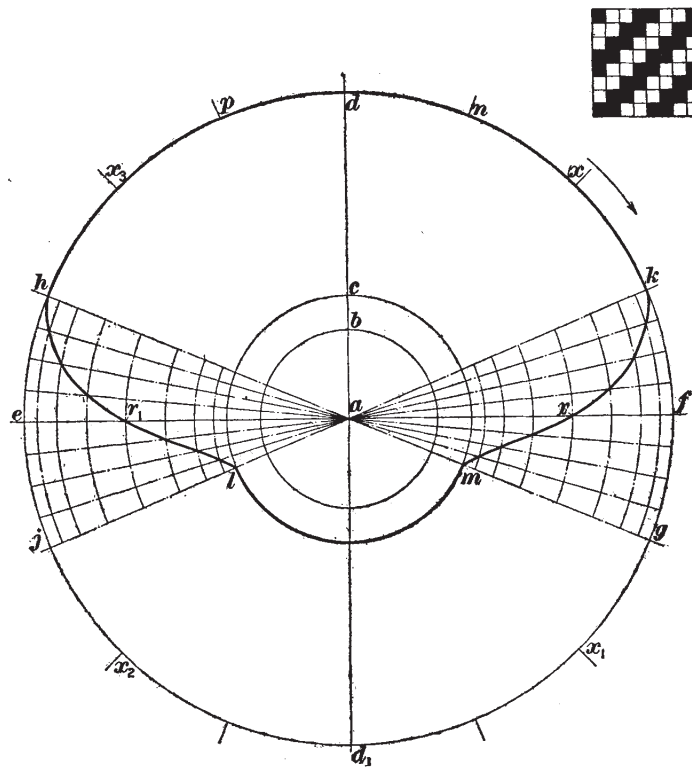

FIG. 2

Connect the points of intersection by means of curves hl and km , which will give the lines of the cam desired.

11. By following the action of this cam through the four picks a clearer idea of its operation may be obtained. It should constantly be borne in mind that the cam makes a complete revolution only once during every four picks.

Considering that the cam is revolving in the direction of the arrow, as shown in the illustration, when the part at m is in contact with the treadle, the cam is just commencing to depress the harness. The lay at this point is coming forwards in its action of beating up the filling, its exact position depending entirely on the setting of the shedding motion. At the point r the two harnesses that are changing are level; at the point k they are entirely changed and a pick of filling is inserted in the cloth while the lay is completing its stroke, or while the cam is moving from k to n . At this point the lay is again just starting on its forward stroke and the loom has completed one pick of the weave, the arc gn being one-quarter of the entire circle and representing the space through which the cam moves during one pick. Another harness is now commencing to be lowered, while still another one is being raised. This, however, is not shown, as only one cam is illustrated and the action of that one only will be followed.

From n to p , the lay is again moving forwards, and from p to h it is on its backward stroke; therefore, when the cam has revolved until the point h is in contact with the treadle, the crank-shaft has completed two revolutions, and consequently two picks have been placed in the cloth.

While the cam is revolving from h to l , the lay is moving forwards for the third time, and before another pick of filling is placed in the cloth the harness is raised. By following the action of the cam while the harness is being raised, or while that part of the cam from h to l is in contact with the treadle, it will be seen that it is similar to that part of the cam from m to k . Owing, however, to the direction in which the cam is revolving, it will be depressing the harness during the time that mk is in contact with the treadle, while it will allow the harness to be raised during the time that hl is in contact with the treadle. The time occupied by the harness in lifting is half a pick, since the arc hj represents the space the cam passes through in this length of time.

The distance from l to m , measured on the circumference of the outer circle, gives the arc jd, g , which is equal to the

arc hdk ; therefore, since the part lm forms the arc of a true circle, its action on the treadles will be similar to that part of the cam formed by the arc hdk , with the exception that in one case the harness will be down while in the other it will be up. Thus, during one complete revolution of the cam, the loom will make four picks, the harness causing the warp ends drawn through it to be raised over two picks of filling and to be under two picks.

FIVE-HARNESS SATIN CAMS

12. Five-harness satin weaves are either warp or filling satins. In the former case, the warp is made to predominate on the face of the cloth, while in the latter the filling will be found to be more prominent. In a five-harness warp satin, the cams are generally constructed in such a manner that four harnesses will be up and one down on each pick, although a warp satin is sometimes woven face down in the loom, in which case there is one harness up and four down on each pick. Cams for five-harness filling satins are so constructed that they will give one harness up and four down on each pick. Fig. 3 shows the construction of a cam suitable for such a weave.

To draw such a cam proceed to draw the circles representing the shaft, hub, and outer throw of the cam. Next divide the outer circle into five equal parts, since five cams are necessary for the weave. The arc fe represents one of these parts. Since the cam is to give the harness a dwell of one-half a pick, one-half of the arc fe should be marked off for the dwell of the cam. This gives the arc fg , but since the harness is to be up during this dwell, the distance fg should be measured on the circle representing the hub of the cam, which gives the arc lm as that part of the cam that gives the dwell to the harness during the pick that it is up.

From the points j, g on the outer circumference, measure distances equal to one-half a pick. This gives the arcs gk, jh , in which to form the change parts of the cam. These

arcs are divided in the same manner as previously described, and the change parts of the cam $m r k$ and $l r, h$ drawn.

By means of these illustrations the construction of any cam for weaving should be readily understood. It should always be borne in mind, however, that the outer circumference, or throw, of the cam is first divided into as many equal

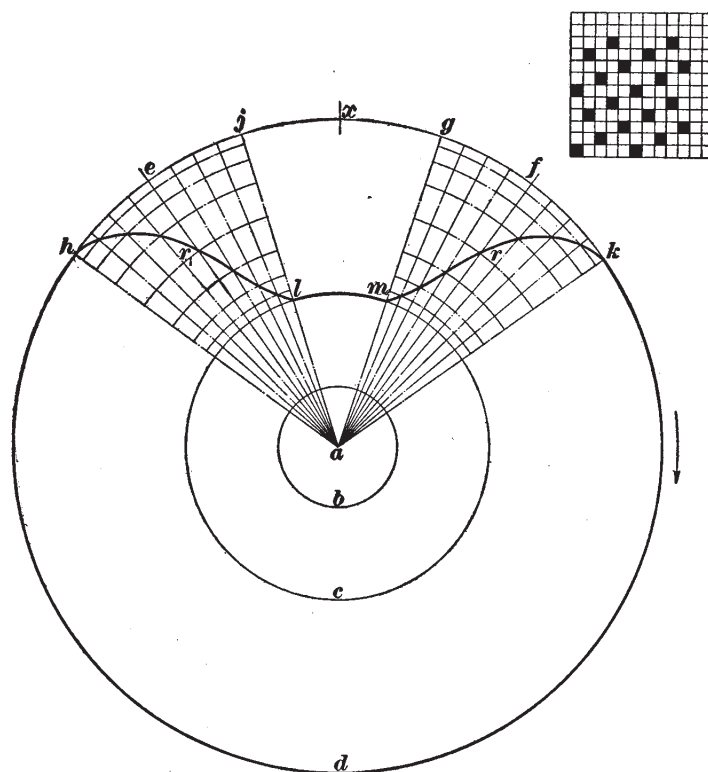

FIG. 3

parts as there are picks to the round in the weave. It should be remembered that one-half the change part of one cam will always overlap one-half of the change part of another cam, and that each cam makes a complete revolution while the crank-shaft is making as many revolutions as there are picks to the round.

ATTACHMENTS FOR THREE-, FOUR-, FIVE-, AND SIX-HARNESS UNDERCAM LOOMS

AUXILIARY SHAFTS

13. As previously stated, a cam makes one complete revolution during the time that it takes the loom to make as many picks as there are cams employed. Thus, in the case of a two-harness cam, each cam makes one revolution while two picks of filling are being placed in the cloth, and since the cam-shaft of the loom makes one revolution while the loom is making two picks, these cams can be fastened to the cam-shaft and they will have the desired speed. When,

however, cams are employed on three-, four-, five-, or six-harness work and it is necessary for each cam to make only one revolution during the time that the loom is making three, four, five, or six picks, it is not possible to operate these cams

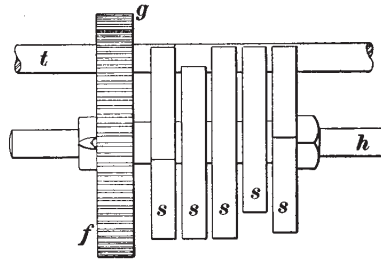

FIG. 4

on the cam-shaft of the loom, which makes one complete revolution during every two picks; therefore, some other arrangement must be employed in order to obtain the right proportion between the revolutions of the cams and the crank-shaft, one revolution of the crank-shaft being equal to one pick of the loom.

When it is desired to operate more than two cams, the cams are setscrewed to a shaft known as the **auxiliary shaft**, which is driven from the cam-shaft by a train of

gears suitable to give the desired speed to the cams. Figs. 4 and 5 illustrate such an arrangement, Fig. 4 being a rear and Fig. 5 a side view of the same motion. The cam-shaft *t* of the loom carries a gear *g* that drives another gear *f* fastened on a shaft *h*, which is known as the auxiliary shaft. This shaft rests in bearings which are supported by

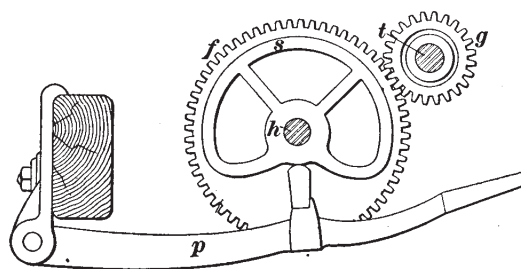

FIG. 5

cross-girts extending from the front to the back girt of the loom. In some cases these bearings are simply supported by rests fastened to the back girt of the loom. In Figs. 4 and 5 the cams are marked *s* and the treadles *p*.

GEARING

14. It is important to consider the gears that drive this auxiliary shaft, in order that the speed of this shaft in relation to the speed of the cam-shaft may be correct. In this connection only the two shafts *t*, *h* are dealt with.

As already explained, the cam-shaft makes one revolution while the loom is running two picks. On the other hand, it is necessary to so drive the auxiliary shaft that it will make one revolution while the loom is running five picks, since it is five-harness work. If convenient, the simplest method of doing this is to have one large-toothed gear on the auxiliary shaft and a smaller gear on the cam-shaft. This is the method adopted in the illustration. In such a case, the calculation for the number of revolutions is simply the proportion of the two gears to each other. The teeth acting

alternately on each other, their relative speeds will be as the number of teeth of one are to the number of teeth of the other. For instance, if it is required to have five picks placed in the cloth while the cam is revolving once, as in this case, then the proportion of the teeth in the gear on the cam-shaft to the teeth of the gear on the auxiliary shaft is as 2 to 5, since the cam-shaft makes only one revolution to every two picks.

To illustrate this, a 60-tooth gear is found on the auxiliary shaft and it is desired to know what gear shall be placed on the cam-shaft in order to give one round of the cam to five picks of the loom. This will resolve itself into the following equation, letting x represent the number of teeth in the gear on the cam-shaft:

$$x : 60 = 2 : 5$$

Multiplying the extremes and means together gives $5x = 120$. Since $5x = 120$, x will be one-fifth of 120, or 24, which will be the required number of teeth in the gear on the cam-shaft. That is, if a 24-tooth gear on the cam-shaft of the loom is driving a 60-tooth gear on the auxiliary shaft, then the loom will run five picks while the auxiliary shaft makes one revolution. By following this method the gears may be obtained for three-, four-, five-, or six-harness work.

15. Another rule for finding the required size of gears on cam-shafts when driving auxiliary shafts may be stated as follows:

Rule.—*Multiply the number of teeth in the gear on the auxiliary shaft by two and divide by the number of picks to the round.*

EXAMPLE.—What must be the gear of the cam-shaft on five-harness work, if the auxiliary shaft has a 60-tooth gear?

SOLUTION.—Applying the rule just stated,

$$60 \times 2 = 120$$

$$120 \div 5 = 24$$

The cam-shaft should have a 24-tooth gear. Ans.

Very frequently it may be found inconvenient to have only two gears. The two shafts are placed at a fixed distance

apart, and the gears must therefore be of such a diameter as to suit this fixed distance; consequently, it will frequently happen that in changing from one number of cams to another, not only the diameter, but the pitch of the teeth, will have to be altered. It is desirable to avoid this as far as possible, and indeed to avoid the necessity of making the gears of such diameter as to suit the distance between the shafts. This is done by introducing an intermediate gear, which becomes simply a medium for communicating the power without in any way altering the relative speed of the two shafts; therefore, the same pitch of teeth may be preserved throughout, and in figuring to obtain the gears the only thing to observe is the relation of the gear on the cam-shaft to that on the auxiliary shaft, leaving the intermediate out of the calculations entirely. In fact, the method is the same as in the first case, where no intermediate was used.

By using a 60-tooth gear on the auxiliary shaft and adopting the intermediate-gear arrangement it is only necessary to change the gear on the cam-shaft when changing from one weave to another, using a 40-tooth gear for three-harness work, a 30 for four-harness work, a 24 for five-harness work, and a 20 for six-harness work. These gears may be kept on the cam-shaft and simply moved into position as desired.

One point, however, to be noted in connection with intermediate gears, is that when such a gear is introduced the direction of motion of the driven gear is opposite to what it is when driven direct from the driving gear. In some cases cams are so constructed that the motion given to the harnesses when being depressed differs slightly from their motion when being raised. When this is the case care should be taken to have the gears so arranged that the shaft carrying the cams will revolve in the right direction. When, however, the motion given to the harnesses in both rising and falling is exactly the same, the direction of motion of the cams does not matter, as the point of contact of the treadle with the cam is directly under the center of the cam.

HARNESS ROLLS

16. It is necessary that some arrangement supplementing the action of the cam be made by which one harness will be raised as another is depressed. The best means of accomplishing this is by means of levers in one form or another, since by their use the *non-positive action* of the cams, as it is called, is converted into a *positive action*. In other words, the cam that can act only in one direction by itself is made to act in both directions through the medium of these levers.

Suppose that only two harnesses are being used: if the harnesses are lowered by the action of the cam, then they may be connected at the top by means of any simple lever or roller, which acts as a lever, so that as one harness is lowered the other, through the medium of this lever or roller, is raised. In this case, the only thing to be considered is that the lever or roller shall be so arranged that the harnesses are not held too far apart, and that the different rollers are of the proper diameters.

ARRANGEMENTS

17. There is not much difficulty in arranging these rollers for any even number of harnesses, the consideration being principally that they shall not spread the harnesses too much. In such an arrangement it is, of course, always necessary that as one harness is depressed another must rise, and there must always be the same number lowered. It does not follow, however, that there must always be just half the harnesses lowered and raised; in fact, there may be any number that is not more than one-half the number of harnesses, but whatever that number is, it must always remain the same.

Whenever the number of harnesses is uneven, a more difficult arrangement must be adopted. It is not different in principle from that employed on an even number of harnesses, but it is different and more difficult to understand when taking into account the question of leverage.

Fig. 6 is an illustration of the harness-roll arrangement on five-harness work; the working of these rollers for each pick of the weave is shown. The weave used is the five-harness satin, with the following order for lifting the harnesses: 1-3-5-2-4.

There are four rollers *a*, *b*, *c*, *d* which may, in fact, be called double, since each has two diameters. The roller *a*

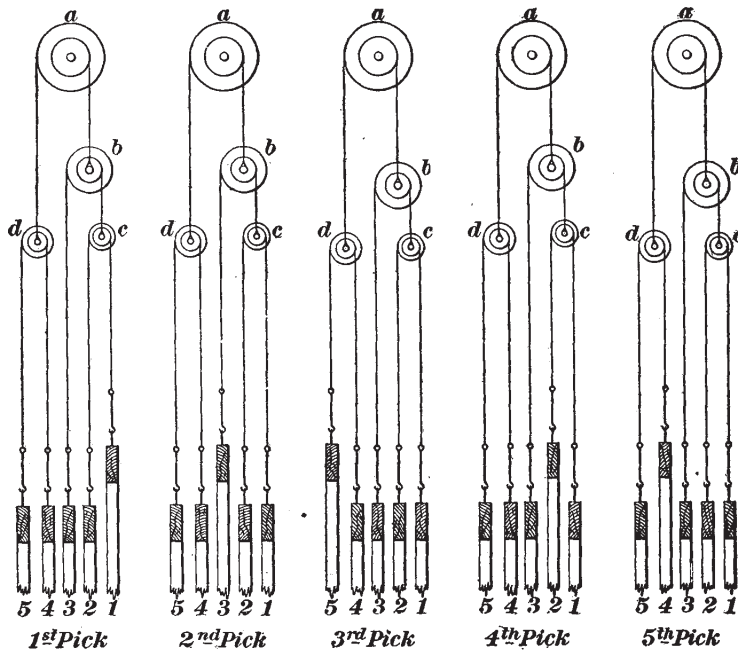

FIG. 6

is fastened to a shaft supported by the arch of the loom. Connected to each of its two faces are straps supporting shafts, on which are fastened the rollers *b*, *d*. These straps simply support the shafts by means of loops and are not fastened in any way, thus permitting the shafts to turn freely as they are acted on by the rollers. The roller *d* supports two harness straps, while the roller *b* has fastened to its larger diameter a harness strap, its smaller diameter

containing a strap that supports another roller c , this last roller in its turn supporting two harness straps.

It will be seen that all the harnesses may be said to be supported from one roller, which in this case is a . It will also be seen that one side of this roller supports three harnesses, while the other supports only two; also, that the roller b , which is supported by a , in its turn supports two harnesses on one side, while it supports but one on the other.

18. By following the action of the cams on these harnesses and rollers, the principles of the arrangement will be understood. On the first pick, the cam allows the first harness to rise; on the second pick, the first harness is lowered while the third harness is raised in the following manner: As the cam acts on the first harness to depress it, the natural tendency of the harness strap attached to this harness is to turn the roller c , but it is prevented from doing this by the harness strap connected to the second harness, this harness being held down by the cam that operates it. Consequently, the motion is communicated to the roller b by the strap connections; the tendency then is to turn this roller.

Since the cam that operates the third harness has revolved until it is in a position to allow the harness to be raised, it is readily seen that the roller b will be turned and the harness lifted.

19. By following the action of the next movement, a slightly different method of leverage will be observed. As the cam depresses the third harness on the third pick, its tendency will be to turn the roller b to which it is fastened, but it is prevented from doing so by the fact that the roller c is held in position by the cams that operate the first and second harnesses. Therefore, the motion is communicated to the roller a by the strap connections, and consequently this roller will be turned. This will tend to lift the roller d , but since the cam that operates the fourth harness will not allow that harness to be raised, the roller d in addition to being lifted will also turn, this being possible through the

fact that it is simply supported by a loop in the strap. This action of the roller d will wind up the strap connected to the fifth harness, and since the cam operating this harness has revolved until it is in a position to allow the harness to rise, the fifth harness will be lifted on this pick.

From these descriptions, it will be seen that the motion of one harness being depressed will be communicated by means of the strap and roller connections to whichever harness the cams allow to rise. It is also evident that rollers can be easily arranged to suit any number of harnesses, but it should be kept in mind, as already pointed out, that they will only serve for patterns where the same number of harnesses is raised for each pick.

To set the cams on work that contains more than two harnesses, turn the crank-shaft until it is on its bottom center; then turn the cams on the auxiliary shaft until the harnesses that are changing are level. Tighten the setscrews on the cams when they are in this position.

SELVAGE MOTIONS

PLAIN SELVAGE MOTION

20. When cloth is being woven in which the ends change only once in three or more picks some arrangement, in addition to the harnesses, must be used in order to produce a selvage, since it is necessary for the ends that form the selvage to change every time the filling is thrown across in order to catch and hold the filling. When the ends interlace frequently with the filling, the **plain selvage motion** may be used. This motion is shown in Fig. 7.

Ordinary plain cams a, a_1 that operate the treadles p, p_1 are placed on one end of the cam-shaft t . Connected to the treadles are straps fastened to a roller c , which is fastened to a shaft d . This shaft extends the entire length of the loom and on each end has a roller e which operates the harnesses f, f_1 . These harnesses pass over a roller g which is held in position by a support fastened to the arch of the loom. The

selvage ends are drawn through these harnesses, and since the harnesses are operated by cams on the cam-shaft they will change at every pick, and thus produce a plain selvage. The cams operating this motion are set the same as cams for plain work.

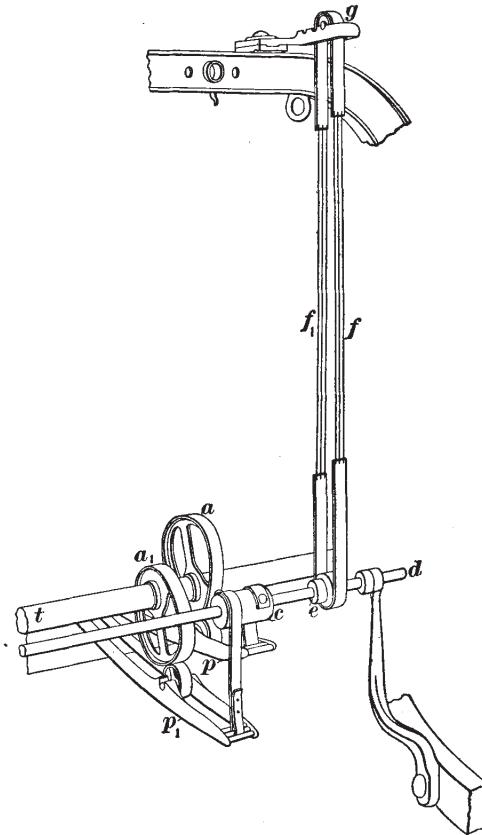

FIG. 7

Instead of having this selvage motion operated by cams and treadles, as shown in Fig. 7, the shaft *d* is frequently given the desired motion by means of an eccentric on the end of the cam-shaft, the eccentric imparting motion to the shaft *d* by means of a connecting-rod.

TAPE SELVAGE MOTION

21. When cloth is being woven in which the filling does not interlace with each end more than once in five picks, as is the case with a five-harness satin, some other arrangement must be used, since if the warp ends are interlacing with the filling only once in five picks and the selvage ends

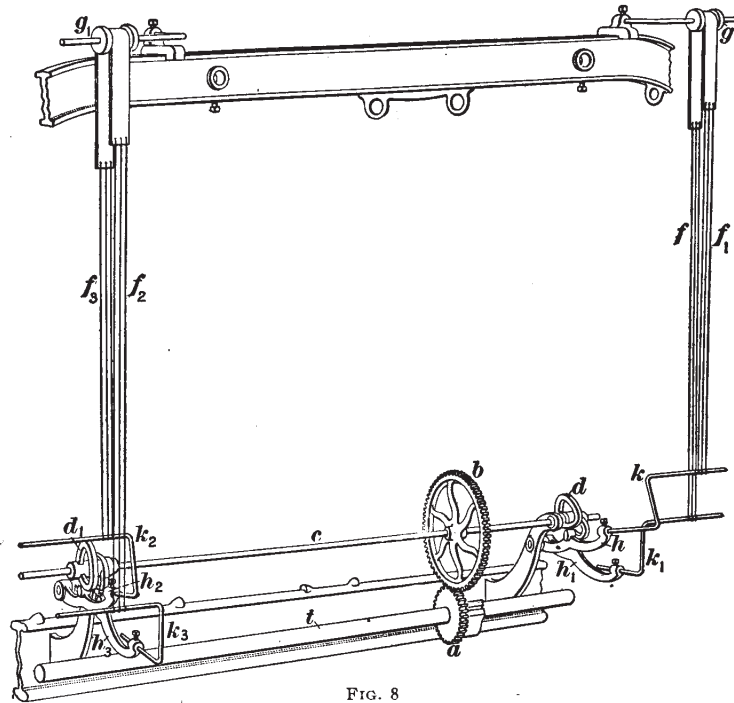

FIG. 8

are interlacing at every pick, owing to the contraction being so much greater on the selvage ends by reason of their more frequent interlacings with the filling, the selvage ends will become so much tighter than the warp ends for the body of the cloth that it will be impossible to weave them. To overcome this difficulty a **tape selvage motion** is used. This motion is shown in Fig. 8.

With this motion two picks of filling are placed in one

shed of the selvage; consequently the selvage ends interlace only once every two picks, yet the selvage will change each time the shuttle is on the side with that selvage; that is, the two selvages change independently of each other, the selvage on one end changing one pick and the selvage on the other end changing the next.

In order to accomplish this, two sets of cams must be employed. Referring to Fig. 8, on the cam-shaft t is a gear a driving another gear b on the shaft c , which extends from one end of the loom to the other. At each end of this shaft is placed a set of cams d, d_1 which operate the treadles h, h_1, h_2 , and h_3 . Connected to the ends of the different treadles are small rods k, k_1, k_2 , and k_3 .

Connected to these rods are the harnesses f, f_1, f_2 , and f_3 , through which are drawn the selvage ends. These harnesses are connected at the top to rollers g, g_1 which rest in supports fastened to the arch of the loom.

The gear b contains twice the number of teeth that are contained in the gear a ; consequently the shaft c will make one revolution while the cam-shaft t , which contains the gear a , is making two revolutions. Thus, the shaft c will make one revolution every four picks.

By setting the cams on each end of this shaft so that one will operate one pick and the other the next pick, and by having the shuttle picking from the side on which the selvage is changing, it is possible to place two picks of filling in each shed of the selvage and yet tie the ends at each pick.

22. Operation.—By considering the action of the cams, this motion may appear somewhat plainer. Suppose the shuttle to be picking from the right-hand side of the loom: Then the cams at d have just operated and the selvage has changed to receive and catch the pick of filling; the shuttle is driven across the loom and the shaft c makes one-quarter of a revolution. As the lay comes forwards for the next pick, the cams on the other side of the loom, or at d_1 , will change the harnesses; but the cams at d will be on the

dwel and therefore will not change the selvage harnesses on their side.

The shuttle is next picked from the left-hand side of the loom, and during this pick the shaft *c* makes another quarter revolution. The cams at *d* will now change the selvage, while the cams at *d*₁ will keep the selvage on the left-hand side stationary. The loom will pick from the right-hand side and the shaft *c* will make another quarter revolution. The shuttle will again be thrown from the left-hand side after the left-hand selvage has changed, and when it reaches the right-hand box the shaft *c* will have made one complete revolution and the harnesses will be in their original position. Thus each selvage end will make only one interlacing with the filling every two picks, yet the filling will be caught by the selvage at every pick.

23. Setting the Cams.—To set the selvage cams on such a motion proceed as follows: With the crank-shaft on the bottom center, set the cams that are on the same side as the shuttle in such a position that the selvage harnesses on that side will be level at that point. Turn the crank-shaft one complete revolution; with the shuttle in the opposite box and the crank-shaft on the bottom center, set the two remaining cams so that the selvage harnesses operated by these cams will be level or just passing each other at this point.

SHEDDING MECHANISM OF A LOOM

24. Fig. 9 shows the complete **shedding mechanism of a loom** suitable for five-harness satin work, the under motion being illustrated. The different parts, together with their letters of reference, are as follows: *x*₂, arch of loom; *a, b, c, d*, top rolls to which harness straps are attached; *q*₈, top harness straps; *q*, harnesses; *k*, harness jacks, which serve as a connection between the bottom straps and harnesses; *q*₇, bottom straps; *r*, front bottom girt; *r*₁, back bottom girt; *x, x*₁, cross-girts, which serve to support the auxiliary shaft; *x*₃, support for the selvage cam-shaft; *h*,

auxiliary cam-shaft; *t*, cam-shaft; *e*, shaft for selvage motion; *s*, five-harness satin cams; *d*₁, selvage cams; *g*, gear on cam-

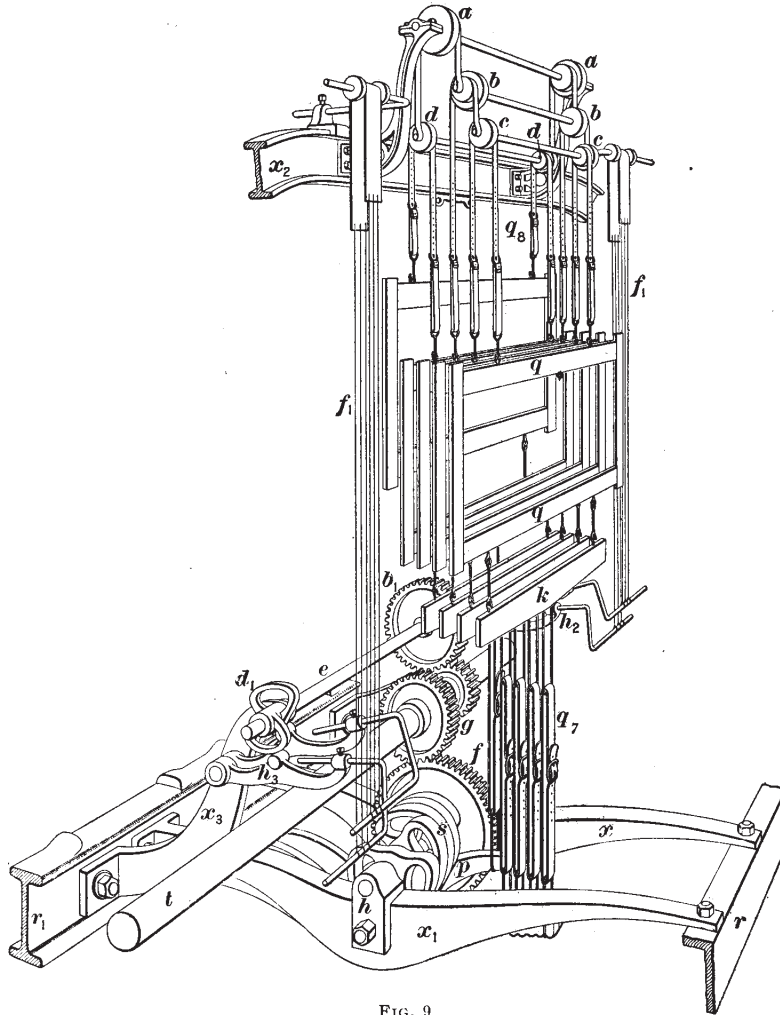

FIG. 9

shaft; *f*₁, gear on auxiliary shaft driven by *g*; *b*₁, gear on selvage cam-shaft; *p*, treadles for the harness motion; *h*₂, *h*₃, treadles for the selvage motion; *f*₁, selvage harnesses.

SIDE CAMS

25. Some looms on four-, five-, or six-harness work have their cams placed at the side instead of under the loom, the claim of the builders being that the cams are much easier to take off and put on when it is desired to change from one class of work to another.

Fig. 10 (*a*) and (*b*) are illustrations of a five-harness side-cam motion, (*a*) being a front and (*b*) a side view; l_1 represents the crank-shaft of the loom, on one end of which is placed the bevel gear h_1 , which drives a larger gear h fastened to a shaft supported by arms extending from the side of the loom. On the shaft with the gear h are placed five cams. The arms c_1 are supported by a shaft passing through them at their central points, this shaft being held in bearings that rest in a support that is fastened to the side of the loom. These arms act as levers and are free to turn on the shaft that supports them. Fastened to the upper end of these levers are the straps d_2 which, passing over the rollers e , are attached to the top of the harnesses. Fastened to the lower end of the levers are other straps d which, passing around the bottom rollers, are connected to the bottom of the harnesses. Connected to each of the levers c_1 is an arm c , to the outer end of which is fastened a roller that works in one of the cams on the shaft driven by the gear h_1 . One cam is shown at s .

It is important to notice that since the cam-shaft contains five cams, it is necessary that it should make one revolution to every five picks; but it will also be noticed that in this case the cam-shaft is driven by a gear on the crank-shaft, which makes one revolution at each pick; consequently the relation of the number of teeth in the gear on the cam-shaft to the number of teeth in the gear on the crank-shaft must be as 5 to 1. In other words, the gear on the cam-shaft must contain five times as many teeth as the gear on the crank-shaft

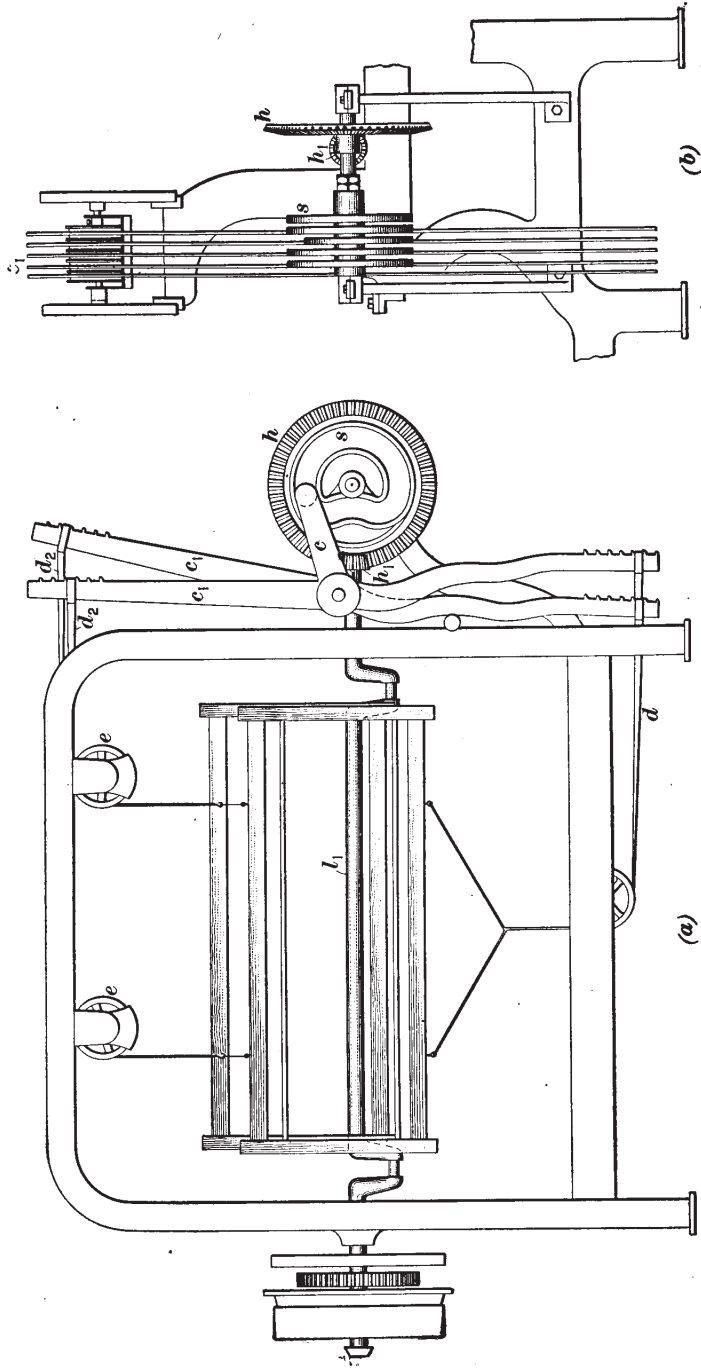

FIG. 10

26. By considering the action of one cam, an understanding of the action of the whole may be obtained. As the cam revolves, the roller that works in it is raised; but since the roller is fastened to the outer end of the arm c , this action will cause the upper end of the lever c_1 to be thrown in toward the loom, while the lower end will be thrown out. By following the strap connections, it will readily be seen that this action will serve to lower the harness operated by this lever. As the cam continues to revolve, the arm c will be brought back to its original position and will thus raise the harness again.

Each cam is setscrewed to the shaft and contains a projection that fits into the cam next to it, so that although the order of the levers lifting the harnesses may be changed, yet the relative position of the cams is easily ascertained. To set the cams on the side-cam loom, proceed in the same manner as with the under motion; that is, set the cams so that all the harnesses which are changing will be level when the crank-shaft is on its bottom center.

CONTINUOUS TAKE-UPS

27. In many cases weavers, instead of regulating the let-off motion when there is not sufficient friction to hold the cloth at a proper tension, roll the slack cloth down by means of turning the take-up gears by hand. This has a strong tendency toward making the cloth uneven; and although it may not show prominently in all classes of work, yet the exact number of picks per inch called for will not be placed in the cloth. To do away with this evil, **continuous take-ups** are applied.

An illustration of this motion is given in Fig. 11. On the cam-shaft is placed a bevel gear b meshing with another bevel gear b_1 on the side shaft c . The side shaft also carries a single-threaded worm d which drives the worm-gear e . The inner side of the gear e carries one-half of a clutch, the other half being attached to the side of the gear g , which has no effect on the drive of this train of gears, but simply

serves as a *let-back motion*. The gear g is known as the pawl ratchet gear. On the same shaft with the gear g is the stud gear j which, through the regular train of take-up gears f (change gears), h , k , and l , drives the sand roll. When the loom is started and the shipper handle brought into its retaining notch, the two halves of the clutch will be in contact; and since the bevel gear b is positively driven by the camshaft of the loom, a positive motion will be imparted to the sand roll and it will be impossible to wind down the cloth by hand so long as the loom is running. With this motion thin places are prevented in the cloth when the loom is stopped

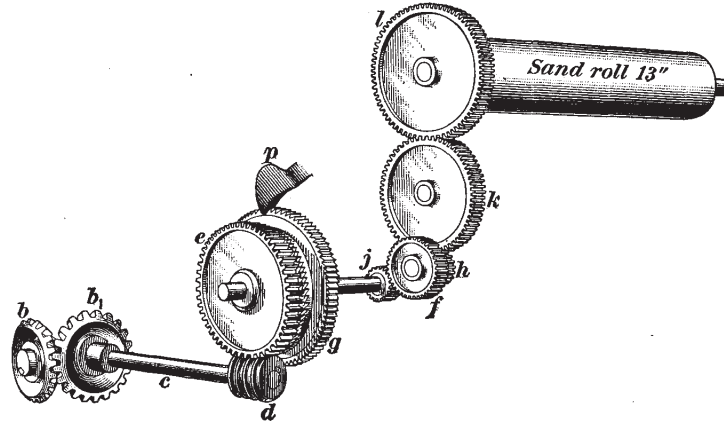

FIG. 11

by the filling running out or breaking, by means of the filling-fork slide acting on the clutch in such a manner as to disengage the two halves. The tension of the cloth then turns the sand roll back a slight distance, the pawl p being pushed back until the end of a slot in the pawl comes in contact with the stud on which the pawl rests, when the gear g is prevented from turning any further. When the loom is restarted, the two halves of the clutch are thrown into gear; and as the gear g is now turned in the opposite direction, the pawl p will drop into the position it occupied before being pushed back.

LOOM ATTACHMENTS

EXAMINATION QUESTIONS

(1) Describe either of the selvage motions illustrated in the text.

(2) Explain the object of a special selvage motion on a five-harness satin weave.

(3) If a loom contained side cams and was running on four-harness work, what gear would have to be placed on the end of the crank-shaft if the gear driving the cams contained 80 teeth, the cams to run one round to four picks?

Ans. 20-tooth gear

(4) If a loom were running on a six-harness satin, what gear would be necessary on the auxiliary shaft if the cam-shaft contained a gear of 24 teeth?

Ans. 72-tooth gear

(5) State the manner of setting the cams on five-harness work to produce a correct shedding action.

(6) If it were desired to construct a set of five-harness cams in which the harnesses remained down three picks and up two, what part of the entire circle would be marked off for the dwell while the harness was down?

(7) State the different orders of lifting the harnesses that would be possible with a set of cams constructed so that one harness would be up and three down on each pick.

(8) Describe the setting of a tape-selvage motion, stating the particular points that should be noted.

(10) Describe, fully, the manner in which a crossing of the ends is made when weaving a pure gauze on a single-lift doobby with top doups.

(11) By what means is the doup end raised when the doup harness is lifted without the standard, bottom doups being used?

(12) When weaving cloth other than pure gauze, what disadvantage does the jumper have?

(13) If you were given a piece of cloth that had the appearance of Fig. 1, would there be any method by which you could tell whether left- or right-hand bottom or top doups were used in its production? Give reasons for your answer.

(14) What is the object of the slackener?

(15) If the distance through which the harness was being moved by the segment on the jumper was too great, how could it be regulated?

(16) Explain, fully, the manner in which a crossing of the ends is made when weaving gauze on a double-lift doobby.

(17) If you were weaving a leno with top doups, when would you operate the slackener?

(18) What particular points should be noted when setting the slackener?

(19) Describe the manner in which the slackener is operated.

(20) State the difference between a right- and a left-hand doup.